

Product data sheet
Double washbasin 950.11.111

HEWI

 **D0V1E**



Double washbasin 950.11.111

- made of mineral composite with non-porous surface, alpine white
- with shelf and round basins
- integrated gripping feature on the side, can be used as a towel holder
- without overflow
- prepared for single hole mixer tap
- wheelchair accessible to DIN 18040 and ÖNORM B1600/1601
- weight capacity to EN 14688
- 1100 mm wide and 550 mm deep
- for hanger bolt fixing
- CE marking according to Construction Products Regulation No. 305/2011



Dimensions in mm

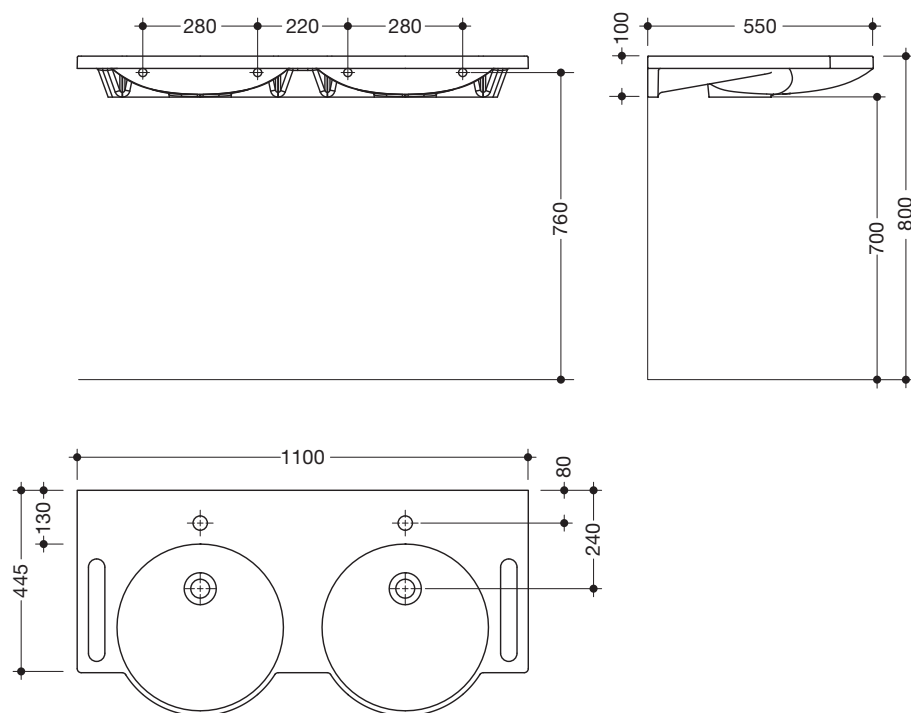

Technical information subject to alteration, 15.06.2015

HEWI Heinrich Wilke GmbH
Postfach 1260
D-34442 Bad Arolsen

Telefon: +49 5691 82-366
Telefax: +49 5691 82-99366
international@hewi.com
www.hewi.com

HEWI (UK) Limited
Holm Oak Barn, Beluncle Halt
Stoke Road
Hoo Kent ME3 9NT

Phone +44 1634 258 200
Fax +44 1634 250 099
info@hewi.co.uk
www.hewi.co.uk