

Product data sheet
Washbasin 950.11.301

HEWI

 **D0V1E**



Washbasin 950.11.301

- made of mineral composite with non-porous surface, alpine white
- rectangular shape
- without overflow
- prepared for single hole mixer tap
- weight capacity to EN 14688
- 600 mm wide, 100 mm high and 500 mm deep
- for hanger bolt fixing
- CE marking according to Construction Products Regulation No. 305/2011



Dimensions in mm

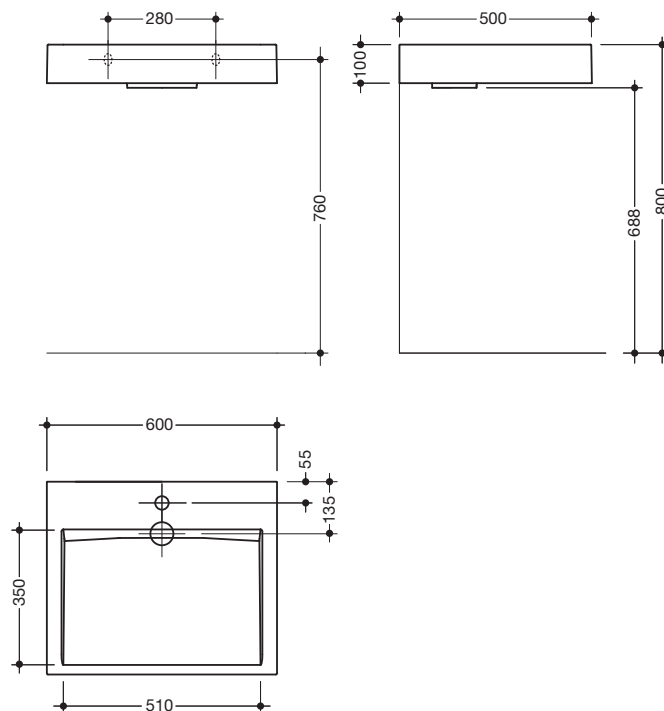

Technical information subject to alteration, 15.06.2015

HEWI Heinrich Wilke GmbH
Postfach 1260
D-34442 Bad Arolsen

Telefon: +49 5691 82-366
Telefax: +49 5691 82-99366
international@hewi.com
www.hewi.com

HEWI (UK) Limited
Holm Oak Barn, Beluncle Halt
Stoke Road
Hoo Kent ME3 9NT

Phone +44 1634 258 200
Fax +44 1634 250 099
info@hewi.co.uk
www.hewi.co.uk