

Product data sheet
Adjustable mirror 800.01.10060

HEWI

 **G1D3E**



Adjustable mirror 800.01.10060

- rectangular plate glass mirror with rounded edges, integrated shatter protection film and tilting frame
- ergonomically shaped handle made of metal, high-quality chrome-plated
- lean and functional with a harmonious, timeless design
- tilting frame with high-quality white coating
- easy adjustment of the tilt between 0 to 10° from a seated position
- for wall mounting
- 580 mm wide, 680 mm high and 115 mm deep
- including non-corrosive HEWI fixing material



Dimensions in mm

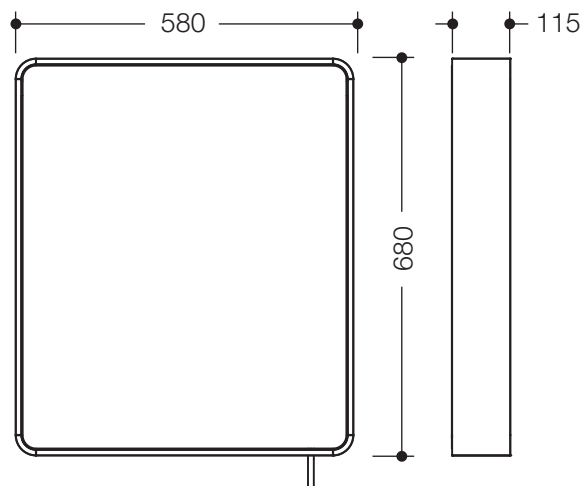

Surface

white

Technical information subject to alteration, 14.06.2015

HEWI Heinrich Wilke GmbH
Postfach 1260
D-34442 Bad Arolsen

Telefon: +49 5691 82-366
Telefax: +49 5691 82-99366
international@hewi.com
www.hewi.com

HEWI (UK) Limited
Holm Oak Barn, Beluncle Halt
Stoke Road
Hoo Kent ME3 9NT

Phone +44 1634 258 200
Fax +44 1634 250 099
info@hewi.co.uk
www.hewi.co.uk